

Refurbishment of Garcimuñoz Castle

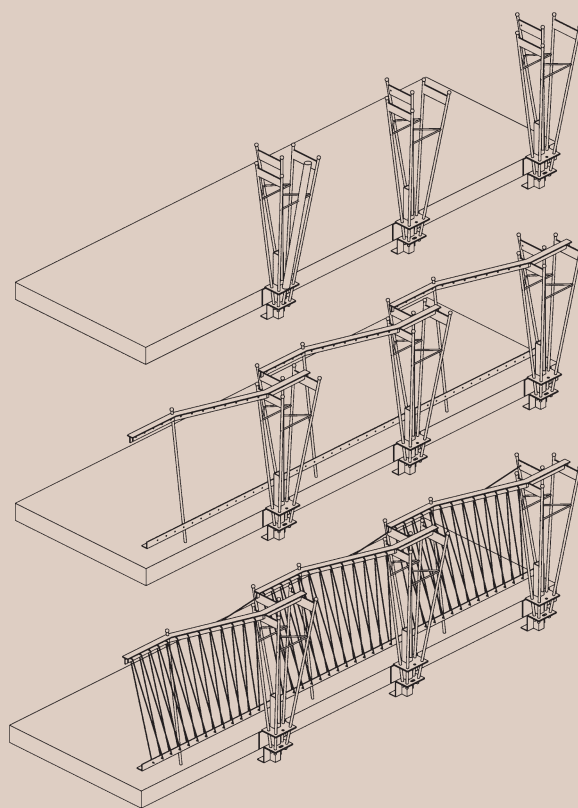

by **Izaskun Chinchilla Architects**

Project Details

Practice:	Izaskun Chinchilla Architects
Designer:	Izaskun Chincilla
Title:	Refurbishment of Garcimuñoz Castle
Output type:	Building
Function:	Indoor and outdoor cultural facilities, including a Media Library
Location:	Garcimuñoz, Cuenca, Spain
Client:	Spanish Ministry of Public Works
Property:	The building is owned by the Catholic Church (now ceded to the Spanish Public Heritage Buildings).
Practical completion:	2014
Dates:	Invited competition organised by the Spanish Ministry of Public Works, 2002; construction, 2010–2013
Funding:	‘10% cultural’ programme, promoted and funded by the Spanish Minister of Public Works
Budget:	€3,335,833
Area:	3,100m ²
Structural consultancy:	FHECOR Ingenieros Consultores and Roberto Marín Sampalo
Service consultancy:	R.ÚRCULO Ingenieros Consultores
Budget, health and safety consultancy:	Julio Hernánz Cabila



.....
Archaeologist: Joaquim Parcerisas Civit
.....

Supervising co-director
for building works: Carlos Jimenez Cenamor (2010–2011)
.....

Execution supervision
assistants: D-fine S.L.
.....

Contractor: CLEOP S.A.
.....

Supervisors from Castilla
La Mancha Heritage: Lorenzo Castellanos and Carlos Villar
.....



.....
Supervisor from the
Spanish Ministry
of Public Works:

Emilio Larrodera

.....
Special supervisor
from the Technical
Building Code:

Javier Sierra

.....
Quality control on site:

Intercontrol Levante S.A.

.....
Management of use:

Castillo de Garcimuñoz Village City Hall

.....

Statement about the Research Content and Process

Description

This innovative refurbishment of the medieval Garcimuñoz Castle reinforces the existing historical structures and transforms them into sustainable and safe spaces for public visits. The design adds contemporary architectural value to the building's heritage and introduces self-sustaining cultural activities supported by digital media.

Questions

- 1. How can new, light and semi-permanent architecture help reveal the different archaeological remains?**
- 2. How can flexible and reversible construction better enable the management of heritage buildings?**
- 3. Can environmental design techniques help heritage preservation by enabling new uses of old spaces without requiring extensive energy consumption?**
- 4. How can the Mediterranean context provide new opportunities for open-air activities?**
- 5. What new economic and cultural opportunities do digital technologies provide for the sustainability of this locally managed historic building?**

Methods

- 1. Studying the lack of public resources in the area and seasonal flows of visitors through national statistics.**

2. Exploring the compatibility of micro-piling with archaeological remains.
3. Environmental design techniques.
4. Structural analysis for meeting relevant legal and safety requirements for public buildings.
5. On-site fabrication tests, e.g. prototyping and manufacturing with digital methods.

Dissemination

Exhibited in Madrid, Tokyo, Istanbul, New York, Brussels, Paris, Rome, Stockholm, Lisbon, Chicago, Houston, Miami and Mexico City. Presented in over a dozen lectures, including in Panama City, Lund and Geneva. Reviewed in books and magazines, including *Arquitectura Viva*, *AV Proyectos*, *Público*, *El País*, *El Mundo*, *Periodista Digital* and *Progettare Architettura*.

Statement of Significance

Chinchilla was awarded Honourable Mention in the arcVision Prize: Women and Architecture 2013, with Garcimuñoz Castle cited as a reason.

Part of El Croquis's permanent collection of Spanish architecture. Selected for the international touring exhibitions *News Trends of Architecture in Europe and Asia-Pacific* (curated by Peter Cook and Toyo Ito) and *Young Architects of Spain* (jury included Kenneth Frampton and Juhani Pallasmaa).

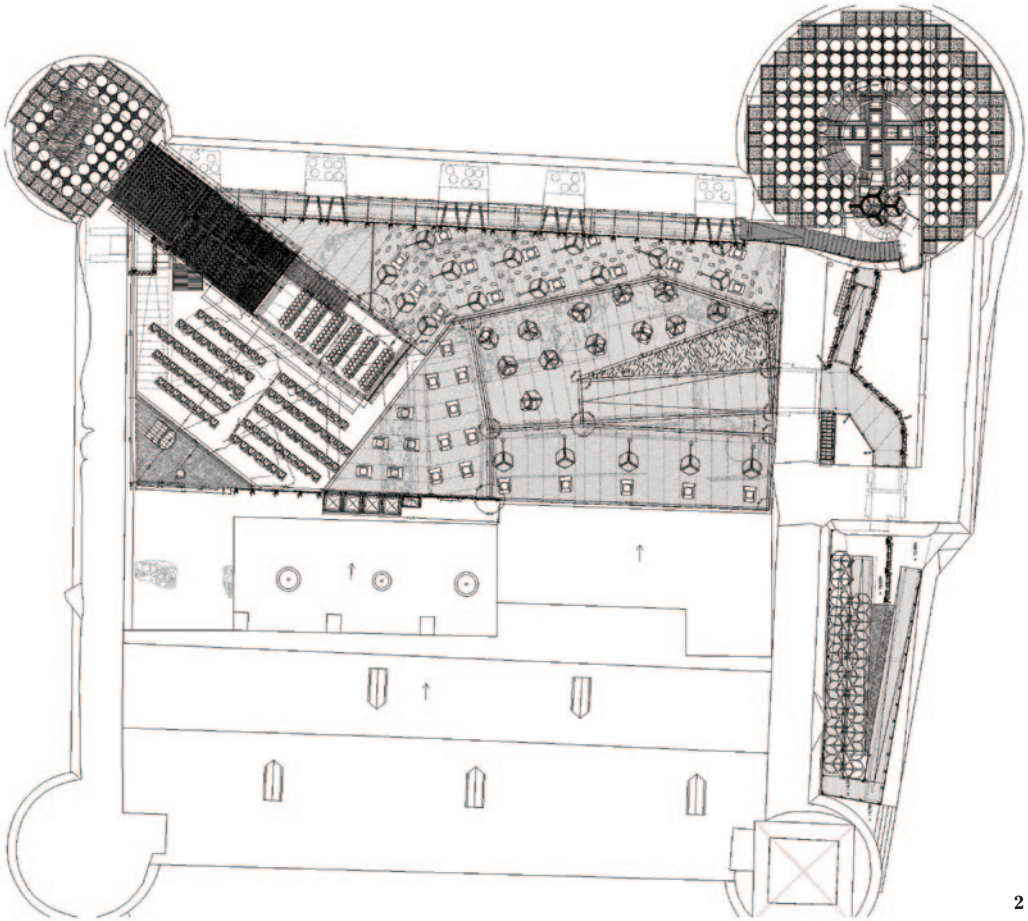

2

2
Roof plan of the project. The intervention affects principally the access to the Entrance Courtyard, the Weapon Courtyard and the Northwest and Homenage Towers.

3
Diagram showing the existing building in the north entrance of Castillo de Garcimuñoz Village



3

Introduction

The Castillo de Garcimuñoz is a medieval castle located in the Spanish province of Cuenca. Its refurbishment consolidates a complex existing group of ruins coming from Arab, medieval and Neoclassical times (10th to 18th centuries). It also incorporates new spaces with innovative functions, including a Media Library.

The refurbishment sought to ensure that the building would be sustainable not only in terms of energy consumption and maintenance costs but also by engaging the local population socially and by creating a venue for renewed cultural and economic activity. [fig. 1–3]

Aims and Objectives

Garcimuñoz's strategic location means it was first the site of a 10th-century Moorish citadel, before becoming the residence of the prominent Villena family in the 12th century and, from 1708, the site of a church which is still in use today. The 3,100m² castle is therefore a complex site of built additions and partial demolitions from different historical periods. The current poor state of conservation makes it difficult to show its full heritage value.

The new refurbishment introduces a network of footbridges, platforms, stairs and rails. Its elements are strategically placed to differentiate the building's different historical periods and to highlight views of building parts from architectural

periods that have not been seen together before. The renovation can be said to work as an orthographic system enabling us to decipher a chaotic and incomplete inherited 'text'. Its aims are multiple:

- To reinforce the existing historical structures and prevent further decay;
- To transform the existing ruins into safe spaces for public visit;
- To add contemporary architectural value to the building's historical value;
- To introduce new self-sustaining cultural and digital activities, compensating for poor local resources. [fig. 4]

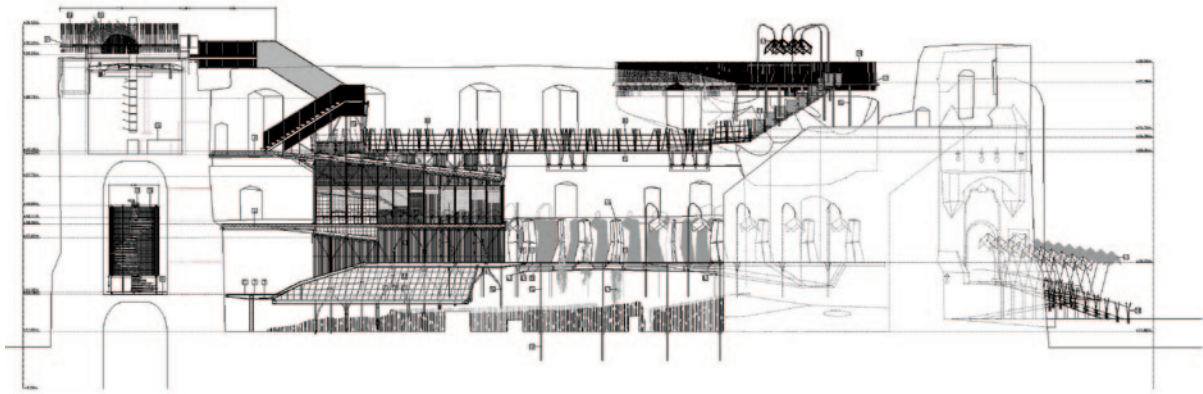

4

4

Longitudinal section through the Weapon Courtyard, showing how the new architectural intervention relates to the different construction periods of the existing

building. The platform covering the Arab ruins is located between the basement built in 11th century and the first floor built in 12th century. The walkway connecting

the towers separates the 13th-century building from the 14th-century building, becoming gradually more palatial and less defensive by introducing bigger windows.

Questions

1. How can new, light and semi-permanent architecture help reveal the different historical and archaeological remains of this site?
2. How can flexible building elements respond to and enable the management of heritage buildings?
3. Can environmental design techniques help heritage preservation by enabling
4. new uses of old spaces without requiring extensive energy consumption?
5. How can the Mediterranean climatic context provide new opportunities for open-air activities?
6. What new economic and cultural opportunities do digital technologies provide for the sustainability of this locally managed historic building?

Context

Spain has one of the highest numbers of castles in Europe: around 2,440 castles and 6,000 pieces of defensive architecture. National Heritage statistics show that only 600 castles are currently in a good state of conservation. This is one of the lowest rates in Europe, despite the funds that the government has dedicated to the refurbishment of many of these buildings. The common approach used in Spain is to structurally reinforce, clean and conserve the ruins of the castles and, in some cases, to transform them into Paradores Nacionales (publicly owned luxurious historical hotels). This strategy is

inadequate for saving the rest of 1,840 castles. New ways of creating income and sustainable maintenance are required that are sensitive to their isolated locations and poor local resources.

This project shows how innovative architectural design can refurbish the castles imaginatively, while also strengthening local economies, enabling public access for all, and supporting their socially and environmentally sustainable use for the long term. It aims to open new strategic visions for the restoration of other castles.



5



6

6
**Structure for the
cinema benches**
Photograph Miguel
de Guzman



7

7
**Mezzandro stool by
 Achille Castiglioni
 (1954)**



8
**Marshmallow sofa by
 George Nelson (1956)**
 Marshmallow Sofa,
 George Nelson 1956, ©Vitra

8

Our research focused on the use of light and demountable structures as a suitable and reversible mode of construction. It also explored the benefits of an interactive digital infrastructure that could help local people of all ages to make continual choices about the production and management of the cultural programme of events in the castle.

The project belongs in the cross-disciplinary field of contemporary design for architectural heritage, paying particular attention to:

Archaeology, museography and architecture

The project researched European Charters on historic buildings and archaeological preservation. It applies the Athens, Venice, Florence and Barcelona Charters on restoration while creating social significance. It applies well-researched 'way-finding' techniques from museography to the complex historical remains of Garcimuñoz Castle.

Building technology and heritage

The project contributes to the broader research field of advancing building technologies for sensitive heritage sites. It achieves remarkable results in the creation of reversible joints and in techniques of construction that allow full dismantling. It also innovates in the use of galvanisation in building restoration and extension.

Overcoming the limitations of building regulations

The project has introduced new technical approaches in the Spanish Technical

Building Code by being considered an experimental case. The Spanish Minister of Public Works commissioned Javier Sierra, one of the Technical Building Code's authors and coordinators, to supervise the project due to its unique experimental character.

Environmental design and programme

Research into the use of solar chimneys, the control of temperature and the use of passive energy is combined with an extensive cultural programme focused on the use of outdoor space and night activities in the summer. The application of these environmental strategies in the field of Spanish architectural heritage and archaeological preservation is unique.

Industrial design

Embedded furniture has been introduced to allow outdoor uses and to incorporate human scale in the historical remains. Particular designs (sofas, chairs, display cabinets, umbrellas, several joints) can be used and applied in other buildings.

Our seating design for the cinema required particular attention to the context of industrial furniture design. We decided that chairs should pay tribute to important pieces of design, particularly George Nelson's Marshmallow Sofa (1956) and Achile Castiglioni's Mezzadro Stool (1954). We collaborated with the local manufacturer Ferroalupal to create new prototypes, substituting the plastic discs originally proposed in these schemes with durable tropical wood. [fig. 5–8]



9

Computer literacy and social engagement

The project brings digital media to a rural area and welcomes people of all ages and abilities to use them. Given that no other Spanish or European initiatives have proposed digital media as an important part of the new uses of castles, the Spanish Minister of Public Works suggested that the Garcimuñoz Castle should be a test case for this. The refurbishment works to integrate and renew cultural programmes within the sensitive setting of the castle by digital means, and to encourage people to proactively determine these programmes through dedicated Internet sites. The Internet is seen as the means of adapting broader cultural trends to local preferences.

Cross-programming and media

The project can be seen among a number of contemporary public buildings that use cross-programming and advanced digital media, such as Toyo Ito's Sendai Mediatheque (2001). The specific programme was developed in consultation with local authorities and other local organisations: Castillo de Garcimuñoz Village City Hall, Castilla La Mancha Heritage and various art institutions and foundations from Castilla La Mancha. All spaces have dual functions: for example, the prism supporting the cinema screen can double as a shallow stage for local village performances and events, and the Library's reading room can be used for seminars. [fig.9]

Job opportunities and local rural economy

In 2009 the Castillo de Garcimuñoz Village population was 171, down from a population of over 1,000 in 1900 (National Statistics Institute), in line with the overall trend of depopulation in the Spanish mainland and in contrast to the rising coastal population. In this context the project aims to contribute to the economic regeneration of the area. Local workers have systematically worked on-site and there is a strategy for encouraging locals to operate the different facilities of the castle.

The EU's sustainable strategy for Spain proposes to strengthen non-agricultural economies in regions that are predominantly agricultural but have significant architectural heritage. However, we are also mindful of critiques of economically determined social sustainability (e.g. Camarero 2009). Bourdieu (2003) and Latouche (2007) have also referred to the economic colonisation of our 'symbolic imaginary'. The project therefore attempts to promote cultural creation within a vulnerable rural context.



10



11

10
View of the Moorish
citadel showing the
colour-coded glass
Photograph Miguel
de Guzman

11
Image taken from the
Moorish citadel. Rows
of columns (60×60mm
steel tubes separated
by 1m) run parallel to

Arab walls remains
and rest on an
H-shaped beam and
removable foundations.
Photograph Miguel
de Guzman

Methods

Heritage and preservation design and building methods

a. Engaging with heritage charters

Responding to the European Charters on historic buildings and archaeological preservation, we researched:

- The use of contemporary materials in refurbishment so that new and old architecture are easy to distinguish (Athens Charter 1931);
- Integration of the social value of monuments in conservation (Venice charter 1964);
- The preservation and enhancement of archaeological structures (Charter for Protection and Management of Archaeological Heritage, prepared by the International Committee for Management of Archaeological Heritage (ICAHM) and approved by the 9th General Assembly in Lausanne in 1990).

Consequently, the new architectural intervention creates a kind of ‘frame’ that lightly reproduces the old spaces but without imitating materials and old building techniques. The rows of light columns, parallel to the existing walls, allow visitors to mentally rebuild the old space; the coloured glass aids historic interpretation in that it uses cold colours for the rooms that were external to the citadel and warm colours for indicating

which rooms were inside the citadel. The effect of light passing through the glass was carefully studied on-site so that the effect does not obscure the archaeological remains and future exhibits. [fig. 10]

b. Adaptable and reversible design

Over the past thousand years, the castle has had many different uses. As Spanish regulations seek to preserve heritage sites ‘forever’, we presume that new uses are still to come. The new constructions are therefore temporary and fully collapsible. The technical implications of this decision have particular outcomes:

Dimensions and weight: The possible dismantling of the new structure requires all joints to be reversible, and each piece to be light and small enough to be carried out of the castle by two people without a crane. Very small steel sections for the columns and beams were designed and placed just one metre apart, dividing the average spans of a normal building into radically smaller distances. The intervention is broken down to smaller-scale units, which are assembled as a kit of parts.

Due to the inconsistency of distances between the building remains, the surveyor Gonzalo Ezpeleta had to determine the measurements for more than 280 uniquely sized columns and beams using 3D scanning and laser control systems. [fig. 11–13]



12

12
The main exhibition
space with the
3.45m-high display
cabinets assembled
by smaller units
Photograph Miguel
de Guzman



13

13
The main exhibition space with a prototype of the display cabinet and of an outdoor umbrella protecting from rain and sun
Photograph Miguel de Guzman



14



15

14 & 15
The foundations
Photograph Miguel
de Guzman

Foundations: 13cm-diameter micro-piles reinforced with steel divide the space and preserve the original structure. Major beams are placed without touching the underlying remains and smaller light columns lie over at one metre intervals. The lightest micro-piling machine on the market was used, which also ensured accuracy in setting out the exact positions. [fig. 14–16]

Canopies and floors: For climatic reasons, the platform covering the Moorish ruins and enabling the view of the medieval castle is composed of two layers: the upper is made out of a steel grid while the lower one is made out of glass hanging from the beams. All hanging details and materials were tested through prototypes and at specialised laboratories, respectively (Intercontrol Levante S.A.). [fig. 17–20]

Northwest Tower staircase: One special case of reversibility is implemented in the Northwest Tower staircase, composed of alternating wood and metal pieces, around a central column. The pieces are held in place by their structural load so that dismantling the staircase is simply a matter of removing pieces from the top down. [fig. 21 & 22]

c. Low-cost environmental design:

Castillo de Garcimuñoz Village City Hall is responsible for the building's maintenance but, with a population of only 180, the village has limited resources. For this reason the project uses economic low-energy principles to minimise maintenance costs.

In order to balance the visitors' fluctuation between summer and winter months, the design proposes a corresponding fluctuation in terms of space use: in mild weather the outdoor areas (e.g. Media Library) increase the useable space to 1,900m². In winter this is reduced to only 250m² of heated area, after taking advantage of the thermal absorption of the existing walls.

The platform's two layers covering the old Weapon Courtyard have environmental significance: the glass retains warmth in the winter (and thereby preserves the remains from low temperature damage) while the tall chimneys ensure cooling in the summer. These glass chimneys act as display cabinets on the upper level and have small skylights that open at the top. [fig. 23 & 24]

d. Optimized galvanisation techniques

The project makes extensive use of galvanised steel. We consulted the Asociación Técnica Española de Galvanización (ATEG) for advice on how best to apply galvanising techniques. Galvanisation is very frequently used in outdoor sports facilities, schools or transport buildings, but rarely in historical buildings. ATEG has surveyed all projects with an outstanding use of galvanisation since 1965 but none of these has a cultural use or significant archaeological value. In this context our project is unique.

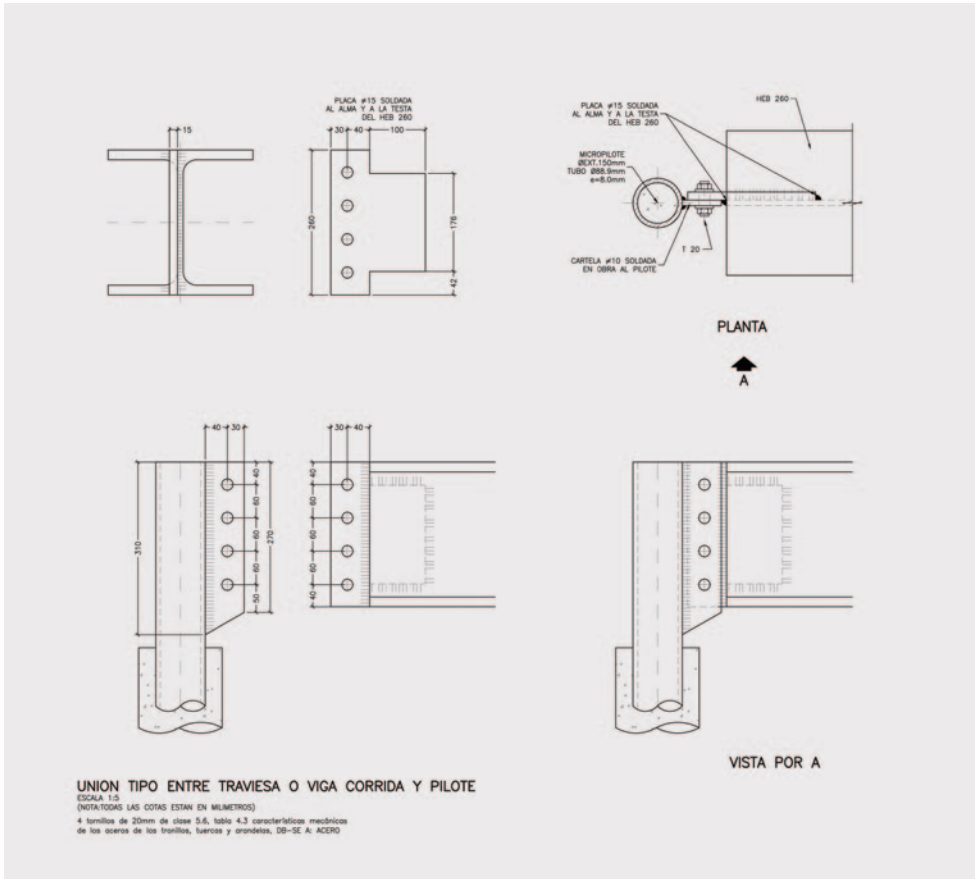

16

Technical detail showing the foundation solution, consisting on an H-shaped beam gathering the loads from the columns and screw to the head of the micro-piles

17

Technical detail of the column and beam joint for the main platform

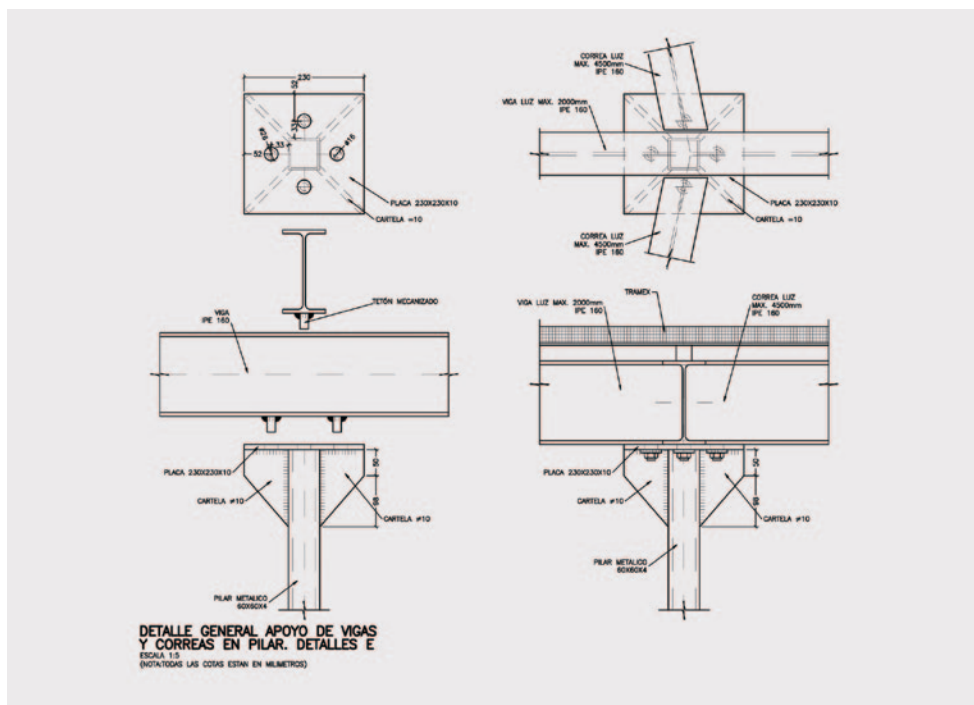

17a

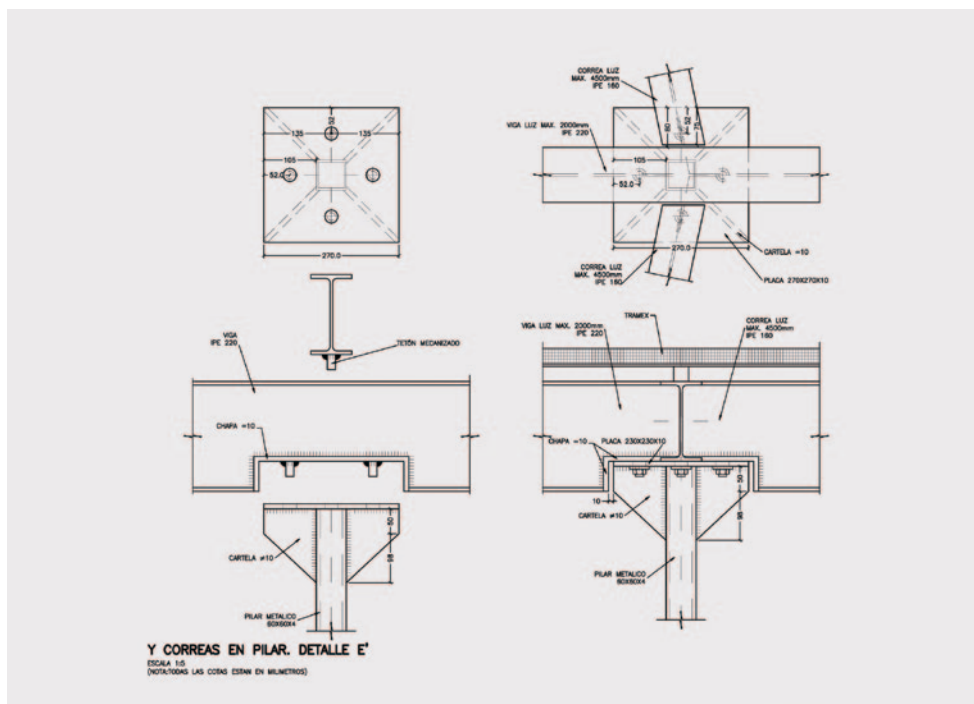

17b



18

18
Beams lay on the
columns without
welding or screws
Photograph Miguel
de Guzman



19



20

19
**The column and
beam joint in
the main platform**
Photograph Miguel
de Guzman

20
**The hanging system
without permanent
fixings between
glass and beam**
Photograph Miguel
de Guzman

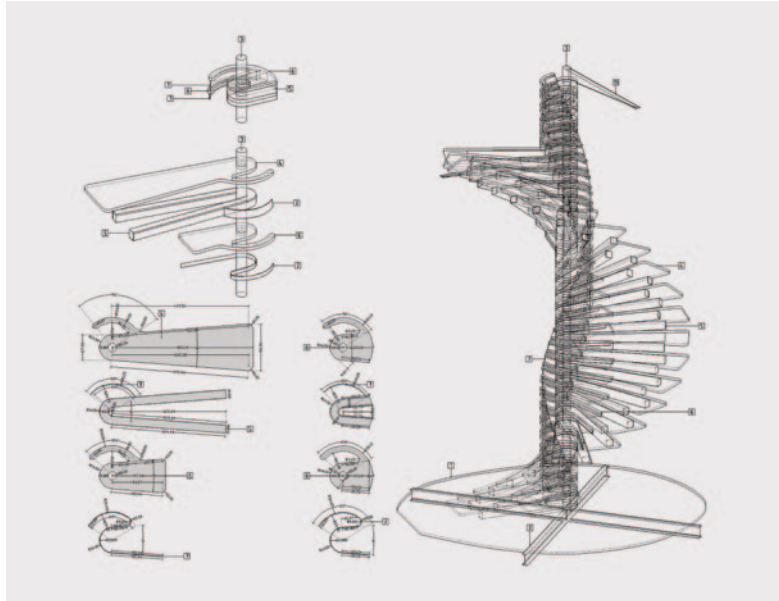

21

21
**Technical detail
 of the Northwest
 Tower staircase**

22
**The bottom of the
 staircase showing
 the wood and metal
 pieces stacked up**
 Photograph Miguel
 de Guzman



22

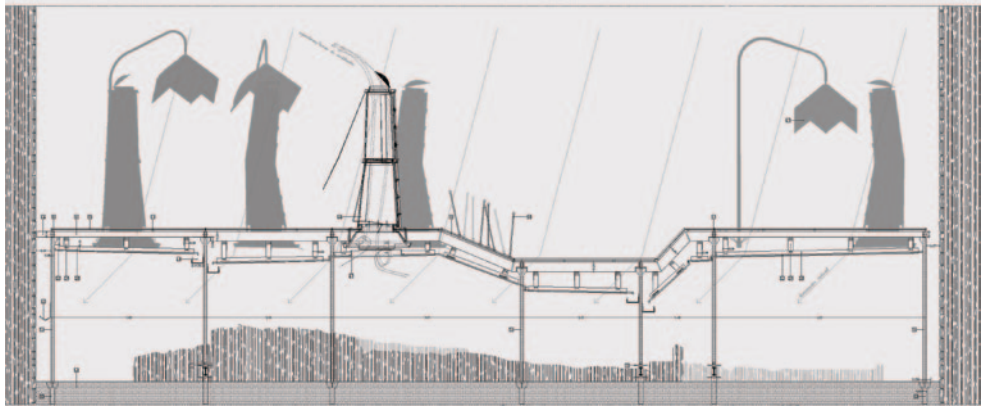

23

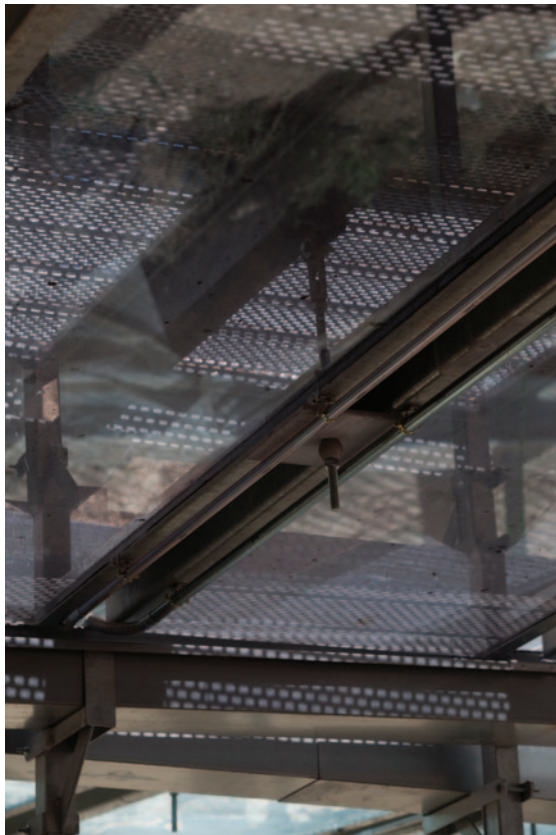

24

23
Cross section by the
Weapon Courtyard

24
The platform covering
the archaeological
remains
Photograph Miguel
de Guzman

The decision to produce a wholly dismountable building meant systematically avoiding welding, which could also damage galvanisation. Extensive research and advanced calculation methods on demountable joints was carried out to determine dimensions and techniques for innovative screw- and clipped-type methods. For example, all the columns in the Weapon Courtyard are fixed with Hilti nails operating by impact. These nails do not affect galvanisation as long as the depth of the metal sheet they attach is smaller than four millimetres. This has compromised the depth of all the columns in the courtyard and has allowed us, with Hilti, to test the structural use of a type of joint that is usually used for interiors. Optimized galvanisation techniques avoid the average welding and painting that dramatically reduce the life span of joints. [fig. 25 & 26]

e. Legal building regulations and technical codes

The Spanish Technical Building Code (TBC) has adopted the most modern international approach to building regulations: performance-based codes. This means objectively identifying the qualitative and quantitative characteristics of the building and through these determining its aptitude to fulfil its different functions. The experimental

techniques and technical outcomes used in the building have a high potential for further application.

Access and fire safety: As the project is based on existing buildings, most of the TBC's recommendations for access were difficult to follow and so a reorganisation of the programme was proposed: mechanical and electrical services are located in easily accessible places; historic spaces are divided into typologies so that all typologies have an example of space that can be reached by everybody; a new lift integrates a panoramic view that is the same as the one gained on the footbridge. Making a medieval castle have continuous disabled access was challenging, but the result is that approximately 80 per cent of the spaces are fully accessible by all. Where the distance made it difficult to ensure good fire evacuation, spaces were organised outdoors.

Handrail design: Extra care was dedicated to handrail design. Instead of blindly following the TBC's basic recommendations, the handrails were divided into multiple independent units, each one with a curved treatment that discourages climbing and sitting. The vertical balusters play with rhythm and a kind of vegetal geometry is produced overall that contrasts with the existing building. [fig. 27–29]

25
Detail of the handrail showing the contrast between galvanised metal and existing stone
 Photograph Miguel de Guzman

26
The walkway joining two refurbished towers, showing the fragmentation of the handrail
 Photograph Miguel de Guzman

27
Detail of the handrail showing how the galvanisation technique is combined with clipped panel joints
 Photograph Miguel de Guzman

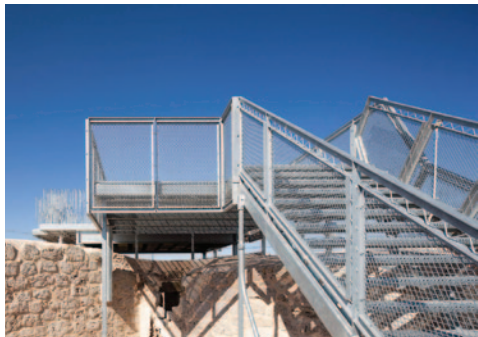

25



26



27

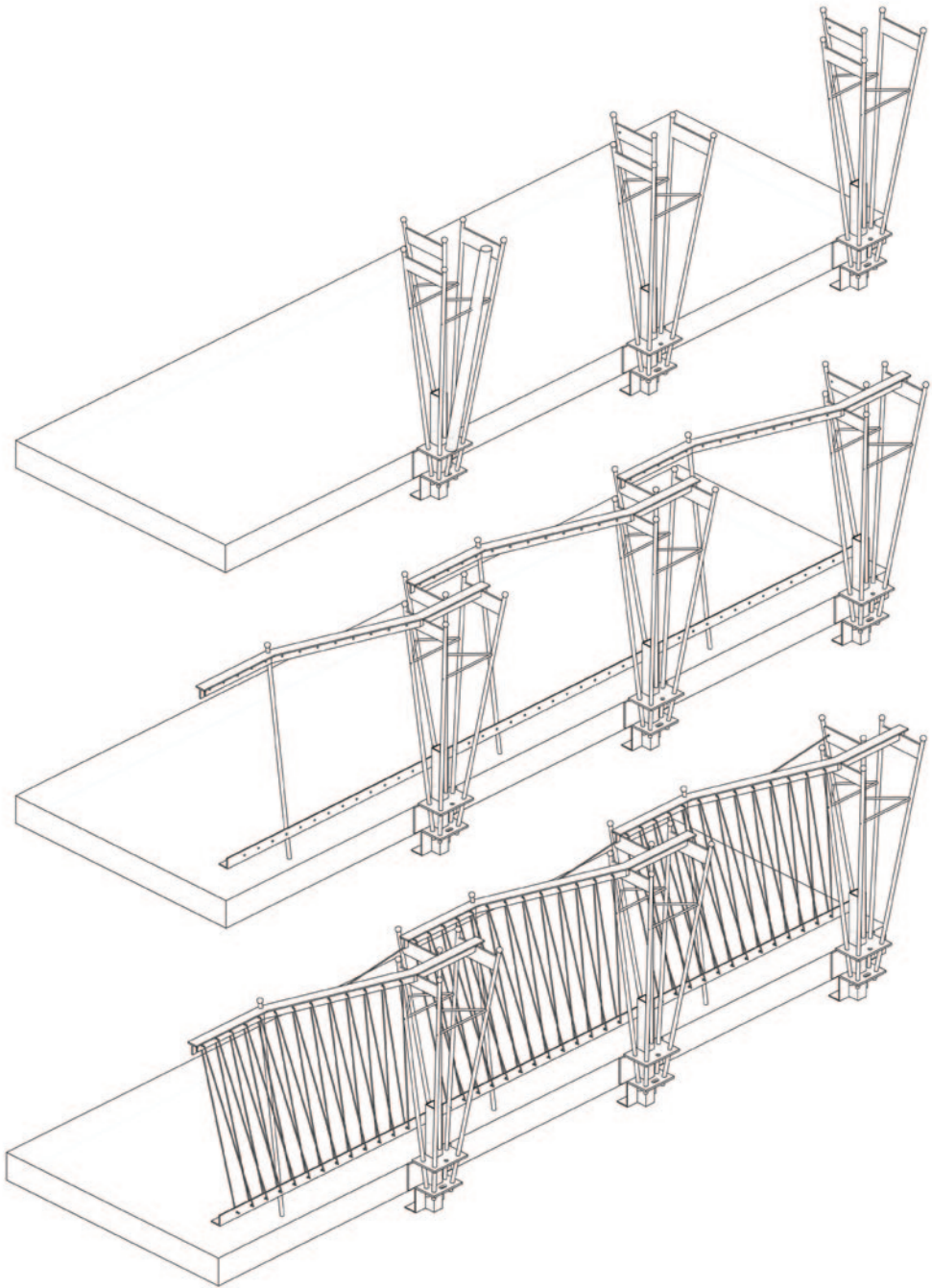

28
Technical detail of
the components of
the handrail



29

29
Local workers mounting
a display cabinet
and an accompanying
umbrella



30

30

The prototype of the display cabinet in the workshop of Ferroalupal, supervised by the structural engineer

31 Prefabricated samples testing solutions for stairs, fabricated by Ferroalupal

32

Prefabricated samples testing solutions for glass panel frames, fabricated by Ferroalupal

f. Prototypes

The complexity and context of the project demanded building production through trial and error and manufacturing through plenty of prototyping. The prototypes were produced in full scale and in the final material with the fabricator Ferroalupal. They were categorised according to complexity and total number of units and their production was phased accordingly. After prototyping, details were drawn and improvements were introduced back into the project. [fig. 30–32]

The second set of prototypes produced by Ferroalupal focused on electrical, wood, glass and plastic details for almost all elements in the project. After prototyping, Intercontrol Levante S.A. checked the satisfaction of legal regulations and gave feedback for further iterations. Finally, a careful production schedule separated on-site and off-site fabrication, taking into account workshop size limitations and transportation issues. [fig. 33]

Socially informed design strategies

a. Flexible programme

All spaces have dual public functions, allowing for great flexibility in use. The programme is complex and composed of:

- Environmentally designed exhibition areas (890m²);
- Outdoor exhibition areas with protective covers (390m²);
- Outdoor cinema (330m², capacity 108 people);
- Video and sound library (42m²);
- Smaller outdoor cinema (38m²);
- Cafeteria, tapas restaurants and kitchen (21m²), and five dining areas (approximately 15m²);
- Library (capacity 45 people);
- Panoramic terraces/bars (180m²);
- Management of Archaeological Heritage (ICAHM) and approved by the 9th General Assembly in Lausanne in 1990).







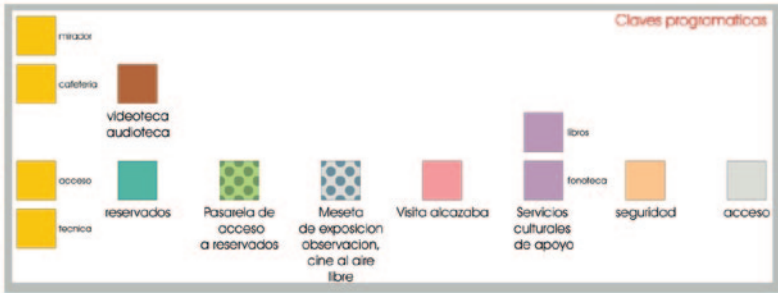
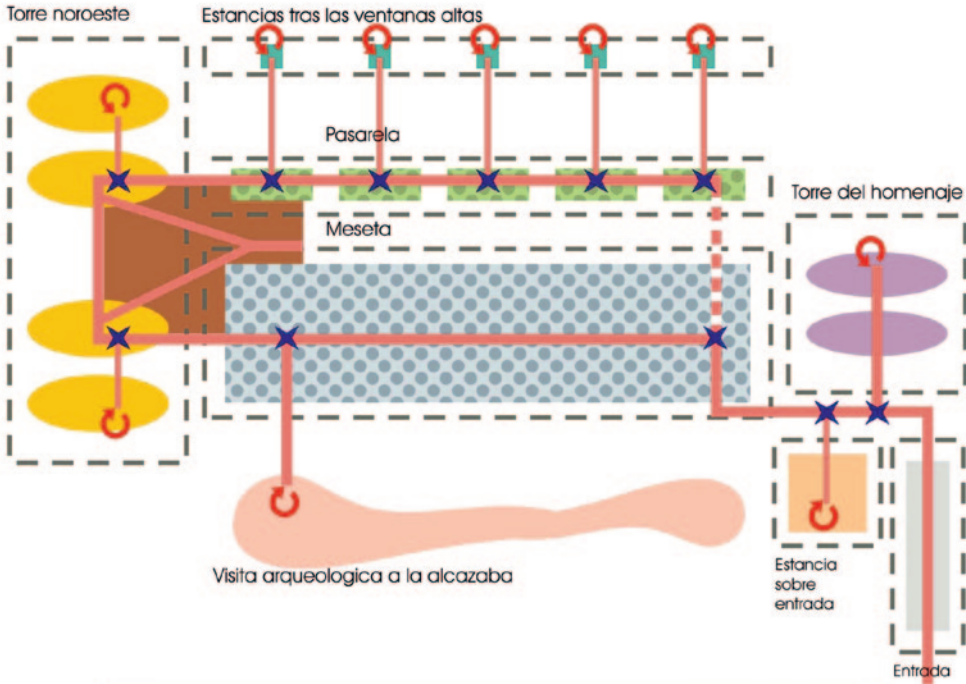

34

34 Routes through the building

35 Library interior in Homenage Tower, and grandstand Photograph Miguel de Guzman



35

b. Social media and participation

Digital technology is explored as a tool to encourage expression of choice and social participation in the curation and production of events. This objective determined the following decisions:

- The 390m² outdoor exhibition area in the old Weapon Courtyard contains 45 display cabinets that will display bottom-up content determined democratically by different participants who express their views in a dedicated associated webpage. The castle's curatorial team will devote a display cabinet for each submitted digital query and encourage self-editing of the display.
- The films played in the outdoor cinema will be curated using public voting on the Internet.
- The video and sound library in the new prism will store films, songs and videos for people of all ages, and help computer literacy by welcoming assistants and volunteers.
- Small groups interested in watching a particular film together will be able to rent, via the Internet, the outdoor smaller cinema on the top of the new prism.

- Local cheese and wine producers will be able to reserve, via the Internet, the five dining areas and two panoramic terraces; when they do so, a schedule will be automatically created to attract visitors interested in tasting the various products on offer.
- The library placed in the Throne Tower, including a grandstand for 45 people, will provide facilities for video lectures, which will also be available online.
- All environmental technologies requiring opening or closing small elements are controlled through simple and inexpensive digital interfaces. [fig. 35]

c. Museography and way-finding techniques

The design integrates the Media Library programme with the existing spaces of historical importance, and uses 'way-finding' techniques to enable visitors to navigate (e.g. Lynch's definition: 'a consistent use and organization of definite sensory cues from the external environment', 1960). Following these techniques and appropriate signage, we have created an itinerary of a circular main route, which has one point of access and exit, with smaller circular itineraries integrated within it. [fig. 34]



36

36
View of the outdoor
cinema in the
Weapon Courtyard.
The playing of
films in the historic
environment is a
unique experience.
Photograph Miguel
de Guzman

d. Mediterranean climate and use of outdoor space

The Mediterranean tradition of external paved areas between buildings encourages flexible, collective and social use: 'Outdoor space was a place where individual cultural values were expressed precisely because the space had to be shared with others professing other values' (Cowan 2000). In warm climates outdoor life, particularly after dark when heat dissipates, is especially important: 'the sound or possibly song of the cricket does not disturb insomnia – I know from experience – on summer nights when waking is easier than sleeping and the spirits keep watch and almost seem to merge over the Mediterranean' (Matvejevic 1999).

The project tries to maintain and recover these traditions by designing multiple external exhibition areas, two outdoor cinemas and two panoramic terraces. The introduction of the outdoor cinema, used principally on summer nights, also looks to preserve a culture of evening public meetings, such as storytelling, that can be considered precedent of cinema and an important landmark of Mediterranean cultural production. [fig. 36 & 37]

e. Accessibility

Extra effort was put in adapting the existing architecture to more recent accessible standards: for example, the entrance and exit ramp is an Italian ramp containing low steps combining a circulation area for disabled visitors; the disabled toilet is placed outside, beneath the ramp, to provide an extra facility for the village; and the lift provides access to the panoramic terrace, all dining rooms, the smaller outdoor cinema and the video and sound library. [fig. 38 & 39]

f. Local employment

The project tries to contribute to the EU agenda on economic sustainability by creating working opportunities for locals through:

- Short-term employment during building construction;
- Medium-term provision of jobs to cover services such as security, cleaning, computer programming and building maintenance;
- Long-term job opportunities for running the exhibitions, shops of agricultural produce, cinemas and cafeteria.





38

37
Principal platform in
the Weapon Courtyard,
including outdoor
exhibitions and cinema
Photograph Miguel de Guzman

38
Double ramp system in
the entrance
Photograph Miguel de Guzman

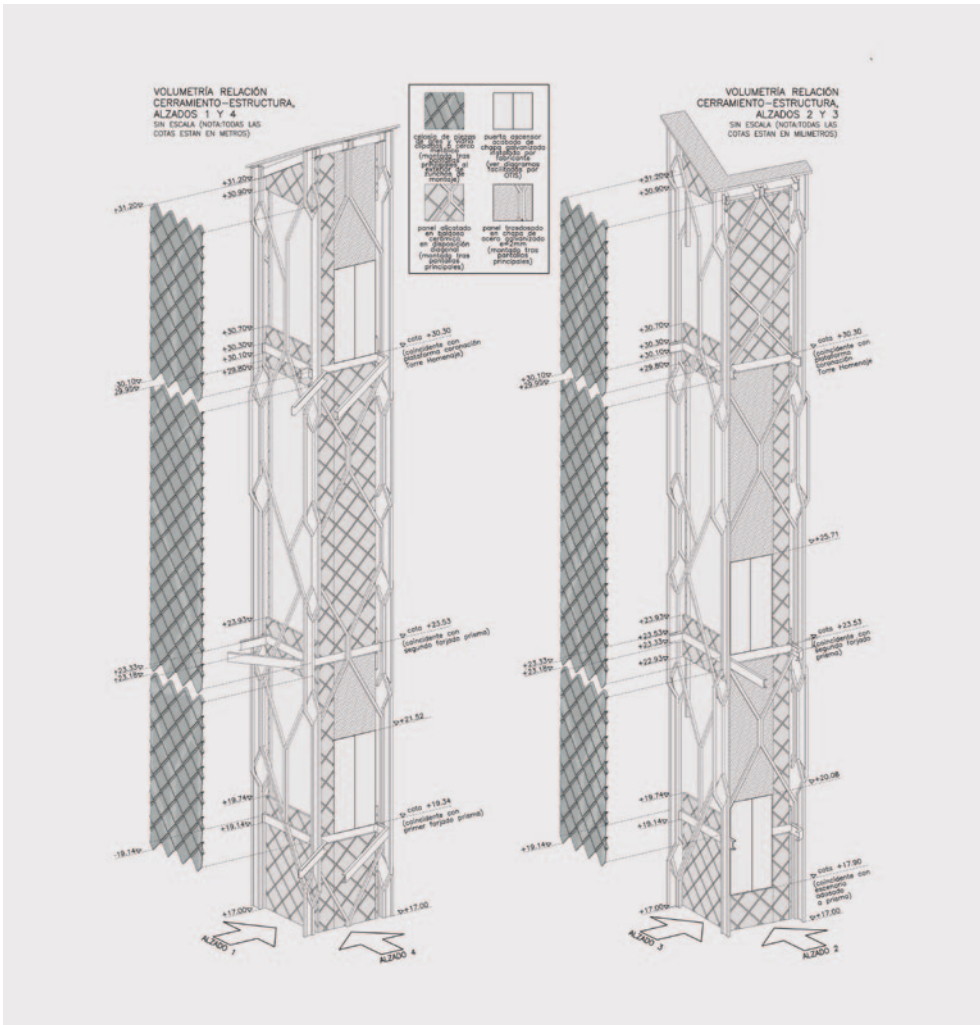

39
Technical detail of lift,
providing disabled
visitor access to
panoramic terrace

Dissemination

The refurbishment of Garcimuñoz Castle forms part of the permanent collection of contemporary Spanish architecture on display at the Madrid headquarters of the architectural magazine *El Croquis*. It has been exhibited in Europe, North America, and Asia, including in:

News Trends of Architecture in Europe and Asia-Pacific (curated by Peter Cook and Toyo Ito): Tokyo (2008); Niigata, Japan (2009); Istanbul (2009); Lisbon (2010-2011).

Young Architects of Spain: A Window to the Unknown (curated by Jesús María Aparicio Guisado and Jesús Donaire García de la Mora; selection jury included Kenneth Frampton and Juhani Pallasmaa): Madrid (2008); New York City (2009); Brussels (2010); Stockholm (2010); Paris (2010); Rome (2011); Chicago (2011); Washington, D.C. (2011); Dallas, Texas (2011); Houston, Texas (2012); Ithaca, New York (2012); Richmond, Virginia (2012); New York City (2012); College Station, Texas (2012); Miami (2013); Carleton, Ottawa (2013).

Casa: Árbol, Chocolate, Chimenea, LIGA Espacio para Arquitectura, Mexico City (2012-2013).

The project has also been presented in over a dozen lectures, including in: Tokyo (2008); San Sebastián, Spain (2010); Panama City (2011); Paris (2011); Lund, Sweden (2011); Geneva (2012); and Madrid (2012). It has been widely reviewed in articles, books and magazines, including: *Arquitectura Viva*, *AV Proyectos*, *Público*, *El País*, *El Mundo*, *Periodista Digital*, and *Progettare Architettura*.

The Garcimuñoz Castle refurbishment was cited as one of the works leading to Izaskun Chinchilla being selected for an Honourable Mention in the Italcementi Group's arcVision Prize: Women and Architecture 2013. The jury included Shaikha Al Maskaru, Vera Baboun, Odile Decq, Victorie de Margerie, Yvonne Farrell, Samia Nkrumah, Kazuyo Sejima, Benedetta Tagliabue and Martha Thorne.

The author has also been invited to participate in a new commission which is being established to organise future building developments that will bring digital facilities to rural areas through building design.

Bibliography

Pierre Bordieu (2003). *Las estructuras sociales de la economía*. Barcelona: Anagrama.

Luis Camarero, et al (2009). *La sociedad rural de España: de los desequilibrios a la sostenibilidad social*. Colección Estudios Sociales 27. Barcelona: Fundación La Caixa. http://obrasocial.lacaixa.es/deployedfiles/obrasocial/Estaticos/pdf/Estudios_sociales/vol27_es.pdf

Alexander Cowan, ed. (2000). *Mediterranean Urban Culture 1400–1700*. Exeter: University of Exeter Press.

Serge Latouche (2007). *Sobrevivir al desarrollo: de la colonización del imaginario económico a la construcción de una sociedad alternativa*. Trans. Patricia Astorga Pérez. Barcelona: Editorial Icaria.

Kevin A. Lynch (1960). *The Image of the City*. Cambridge, Massachusetts: Technology Press.

Predrag Matvejevic (1999). *Mediterranean: A Cultural Landscape*. Trans. Michael Henry Heim. Berkeley and Los Angeles: University of California Press.

40
View from the
entrance to the Castle
 Photograph Miguel
 de Guzman

41
View from the
Moorish citadel
 Photograph Miguel
 de Guzman



40



41



42

42
View of the main platform with display cabinets
 Photograph Miguel de Guzman

43
View from the walkway joining both towers in the North façade
 Photograph Miguel de Guzman

44 (overleaf)
View from the walkway joining both towers in the North façade
 Photograph Miguel de Guzman



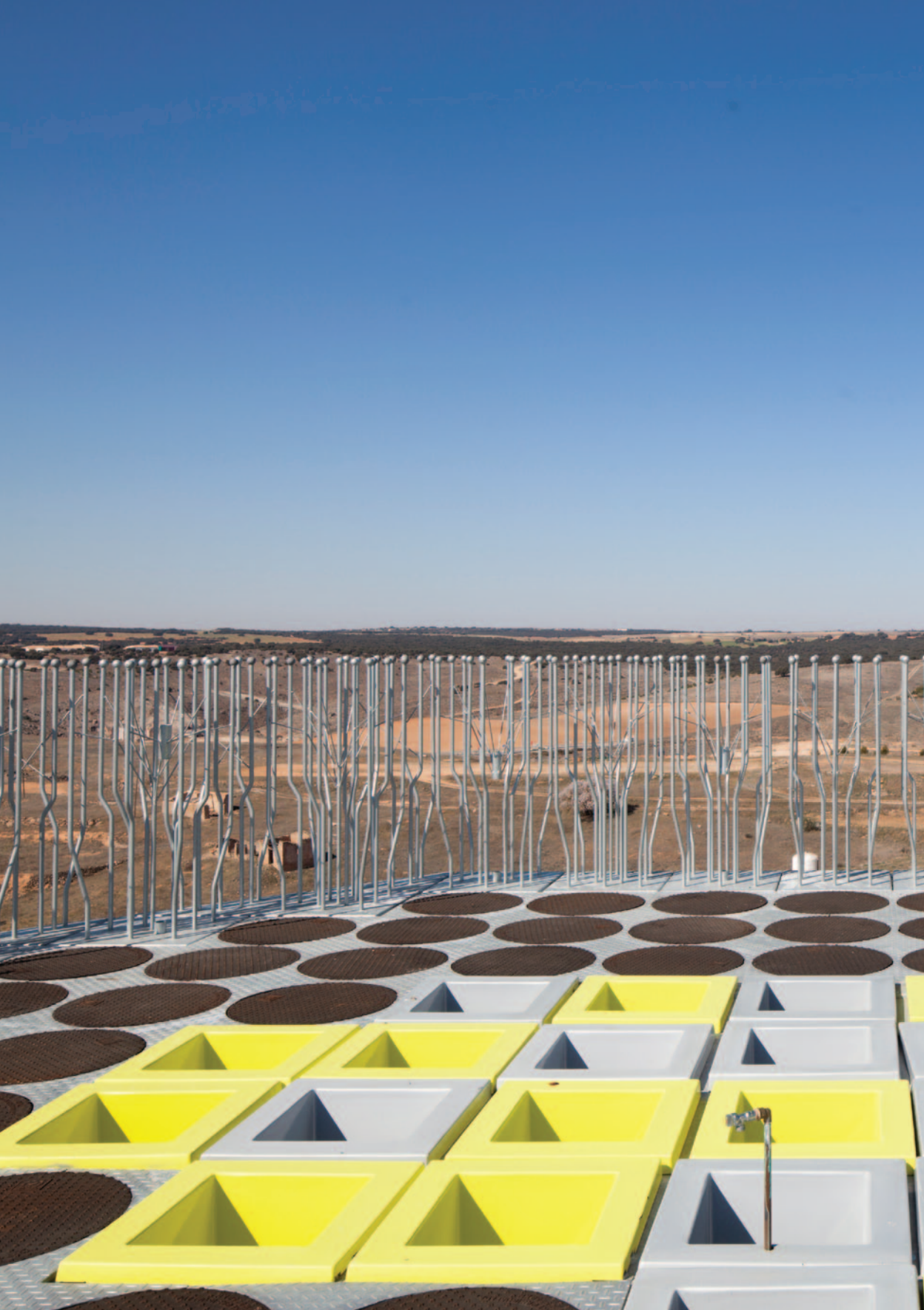

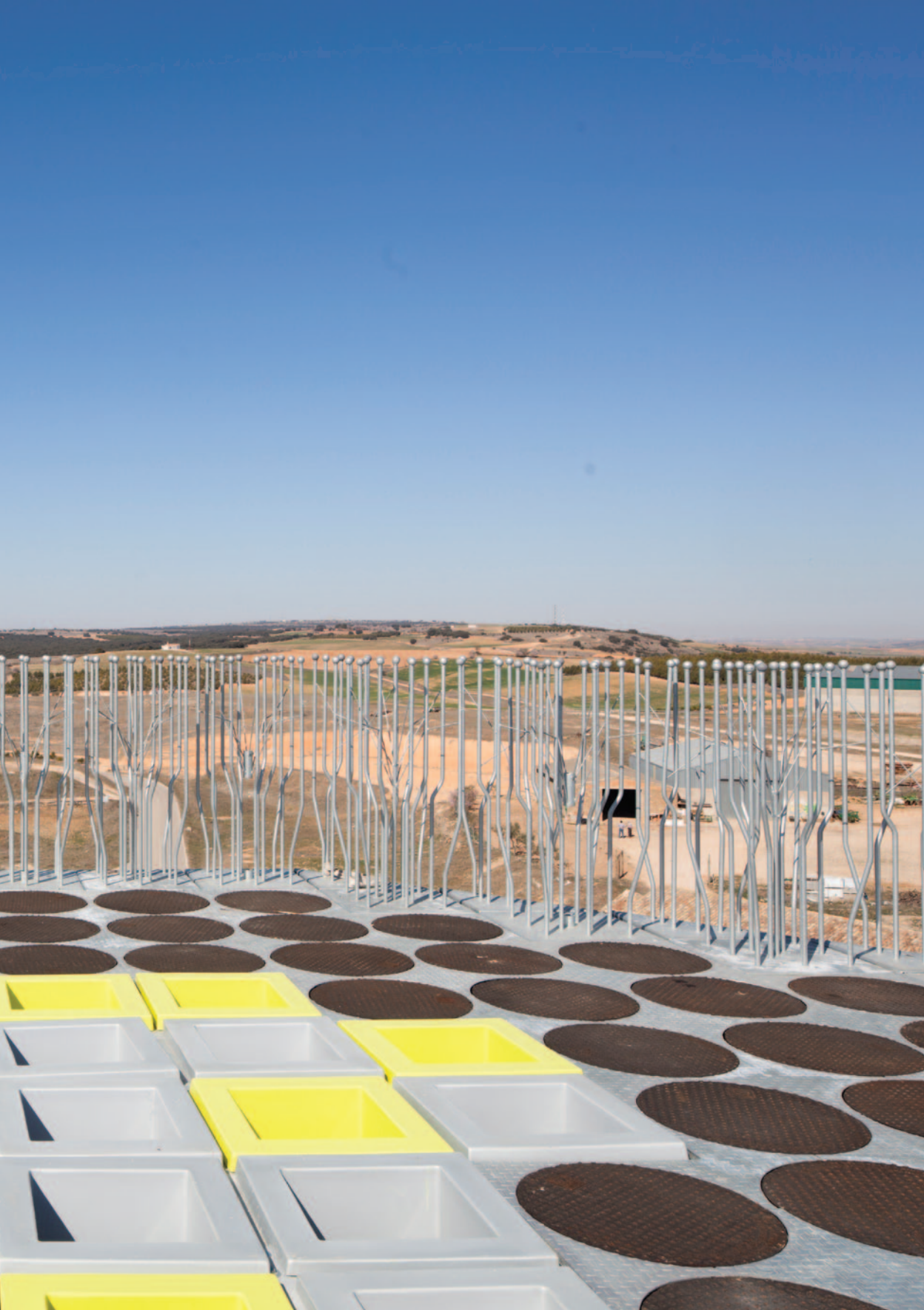

Related writings by others

Prize

pp. 45–54

Italcementi Group, *arcVision Prize 2013–Women and Architecture* [catalogue] (Mar 2013): 16–22.

pp. 55–56

‘Architect Carla Juaçaba wins the arcVision Prize–Women and Architecture’, *Italcementi Group* (8 Mar 2013): www.italcementigroup.com/ENG/Media+and+Communication/News/Building+and+Architecture/20130307.htm

pp. 57–59

‘arcVision Prize–Women and architecture 2013–Honourable mention’, *Italcementi Group* (8 Mar 2013): www.italcementigroup.com/NR/rdonlyres/85C61DB2-48B4-4662-9CE9-36226241764D/0/3Scheda_NOMINATION_chinchilla.pdf

Journal articles

pp. 60–63

‘Castillo de Garcimuñoz Cuenca: Cultural center in a medieval castle’, *Arquitectura Viva* 148 (Jun 2013): 8–9.

pp. 64–84

‘Castle rehabilitation, Castillo de Garcimuñoz, Cuenca’, *AV Proyectos* 50 (Jun 2012): 90–110.



45

45

View of the
Weapon Courtyard

Photograph Miguel
de Guzman

Book chapters

pp. 85–89

'Refurnishment of the Garcimuñoz Castle including a Mediatheque', *New Trends of Architecture in Europe and Asia-Pacific 2008-2010*. Ed. Kawase Yukio and Maeda Rei. Tokyo : Gendai Kikakushitsu, 2008: 8–14.

pp. 90–96

Jesús Donaire, 'Izaskun Chinchilla Moreno. Restoration works at Garcimuñoz Castle, Cuenca', *JAE: Jóvenes Arquitectos de España / Young Architects of Spain*. Ed. Jesús María Aparicio Guisado and Jesús Donaire García de la Mora. Madrid: Ministerio de Vivienda. Secretaría General Técnica Centro de Publicaciones, 2008: 194–201. [The book also includes reviews of Izaskun Chinchilla's work written by Kenneth Frampton, Juhani Pallasmaa, Alberto Campo Baeza, Manuel Blanco Laga, Jorge Otero Pailos and Eduardo Vivanco Antolín.]

Newspaper and magazine articles

p. 97

Chema R. Morais, 'El opuesto a construir no es destruir, sino rehabilitar' [The opposite of build is not destroy, but rehabilitate], *Heraldo de Aragón* (18 May 2013): 72.

pp. 98–99

Carmelo Rodríguez, 'Reutilizar es una necesidad [Reusing is a priority]', *Público* (20 Oct 2008): 32. www.publico.es/culturas/166648/izaskun-chinchilla-reutilizar-es-una-necesidad

Online reviews

pp. 100–101

'Garcimuñoz 14', *Progettare Architettura* (8 Mar 2013): www.progettarearchitettura.it/2013/03/08/garcimuno-14

pp. 102–103

'Garcimuñoz 14', *Archilovers* (11 Mar 2013): www.archilovers.com/p80113/GARCIMU%C3%91OZ14

pp. 104–106

Alexandra Molinare, 'LIGA 07 / Casa: árbol, chocolate, chimenea / Conferencia Izaskun Chinchilla', *Arch Daily México* (29 Oct 2012): www.archdaily.mx/event/liga-07-casa-arbol-chocolate-chimenea-conferencia-izaskun-chinchilla

p. 107

'Siete proyectos arquitectónicos de C-LM son seleccionados entre los mejores de la arquitectura joven de España' [Seven architectural projects in Castilla la Mancha region have been selected between the best works of Spanish young architects], *Periodista Digital* (12 Sep 2008): www.periodistadigital.com/old/982353.shtml

Bartlett Design Research Folios**ISSN 2753-9822****Founding editor:
Yeoryia Manolopoulou****Editors:
Yeoryia Manolopoulou,
Peg Rawes, Luis Rego****Content:
© the authors****Graphic design:
objectif****Typesetting:
Axel Feldmann, Siaron Hughes,
Alan Hayward****Proofreading:
Wendy Toole**

Bloom

by Alisa Andrasek
and José Sanchez

House of Flags

by AY Architects

Montpelier Community

Nursery

by AY Architects

Design for London

by Peter Bishop

2EmmaToc / Writtle Calling

by Matthew Butcher
and Melissa Appleton

River Douglas Bridge

by DKFS Architects

Open Cinema

by Colin Fournier
and Marysia Lewandowska

The ActiveHouse

by Stephen Gage

Djâ vu

by Penelope Haralambidou

Urban Collage

by Christine Hawley

Hakka Cultural Park

by Christine Hawley,
Abigail Ashton, Andrew
Porter and Moyang Yang

House Refurbishment

in Carmena

by Izaskun Chinchilla
Architects

Refurbishment of

Garcimuñoz Castle

by Izaskun Chinchilla
Architects

Gorchakov's Wish

by Kreider + O'Leary

Video Shakkei

by Kreider + O'Leary

Megaframe

by Dirk Krolkowski
(Rogers Stirk Harbour
+ Partners)

***Seasons Through the
Looking Glass***

by CJ Lim

Agropolis

by mam

Alga(e)zebo

by mam

Chong Qing Nan Lu Towers

by mam

ProtoRobotic FOAMing

by mam, Grymsdyke Farm
and REX|LAB

Banyoles Old Town

Refurbishment

by Miàs Architects

Torre Baró Apartment

Building

by Miàs Architects

Alzheimer's Respite Centre

by Níall McLaughlin
Architects

Bishop Edward King Chapel

by Níall McLaughlin
Architects

Block N15 Façade,

Olympic Village

by Níall McLaughlin
Architects

Regeneration of

Birzeit Historic Centre

by Palestine Regeneration
Team

PerFORM

by Protoarchitecture Lab

55/02

by sixteen* (makers)

***Envirographic and
Techno Natures***

by Smout Allen

Hydrological Infrastructures

by Smout Allen

Lunar Wood

by Smout Allen

Universal Tea Machine

by Smout Allen

British Exploratory

Land Archive

by Smout Allen
and Geoff Manaugh

101 Spinning Wardrobe

by Storp Weber Architects

Blind Spot House

by Storp Weber Architects

Green Belt Movement

***Teaching and Learning
Pavilion***

by Patrick Weber

Modulating Light and Views

by Patrick Weber